

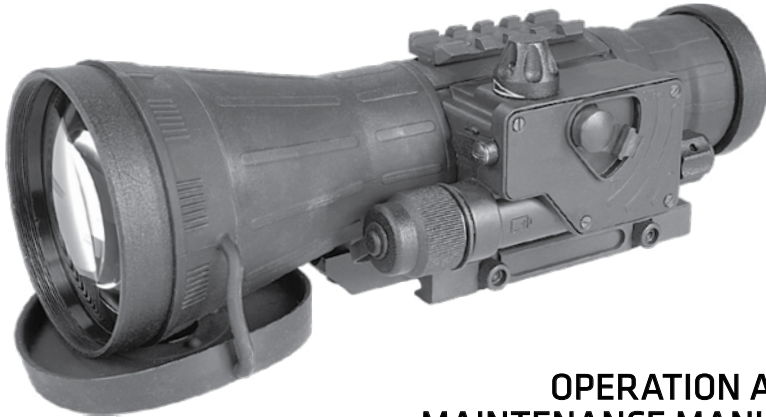

CO-LR CO-LR MG

Night Vision Clip-On Systems



OPERATION AND MAINTENANCE MANUAL

Important Export Restrictions! Commodities, products, technologies and services of this manual are controlled by the U.S. Department of State Office of Defense Trade Controls, in accordance with International Traffic in Arms (ITAR), Title 22, Code of Federal Regulations Part 120-130 and/or by the Export Administration Regulations (EAR) of U.S. Department of Commerce. At any time when a license or a written approval of the U.S. Government is applicable to it, it is illegal and strictly forbidden to export, intend to export, transfer in any other manner whatsoever, sell any hardware or technical data, provide any associated service to any non-U.S. resident, beyond or within the United States territory, until the valid license or written approval has been issued by the Departments of the U.S. Government having jurisdiction. Additionally U.S. law prohibits the sale, transfer, or export of items to certain restricted parties, destinations, and embargoed countries, as identified on lists maintained by the U.S. Department of State, the U.S. Department of Commerce, and the U.S. Department of Treasury. It is the responsibility of the Customer to be aware of these lists. The sale, transfer, transportation, or shipment outside of the U.S. of any product prohibited or restricted for export without complying with U.S. export control laws and regulations, including proper export licensing, documentation or authorization, is unlawful and may result in civil and/or criminal penalties and/or constitute a federal crime. Diversion contrary to U.S. law is strictly prohibited.



SAFETY SUMMARY

Before operating this product, carefully read and study this Operation and Maintenance Manual.

The Armasight CO-LR Night Vision Clip-On System is a precision electro-optical instrument and requires careful handling. To avoid physical damage and damage to the equipment, follow all WARNINGS, CAUTIONS and NOTES.

Below you will find definitions of the alerts that appear throughout this Manual:

WARNING – Identifies a clear danger to the person operating the equipment.

CAUTION – Identifies risk of damage to the equipment.

NOTE – Serves to highlight essential procedures, conditions, and statements, or convey important instructional data to the user.



WARNING:

Always make sure your firearm is unloaded before you place the scope on the firearm. Verify that the chamber is empty, particularly if you stop the procedure and resume at a later time. Safe handling rules should be followed at all times.



WARNING:

If a scope is mounted too far to the rear of a weapon, the eyepiece can injure the shooter's brow. Shooting at an uphill angle also increases this risk, because it shortens the distance between the brow and the rear of the scope. When mounting your scope, we recommend positioning it as far forward in the mounts as possible.

With hard-recoiling rifles, serious injury or even death can result from eyepiece impact when discharging the firearm.

BEFORE SHOOTING THE FIREARM, verify that your installation provides sufficient space between the eyepiece and the scope to account for the recoil generated by your rifle.

NOTE: Give special attention to this warning when shooting uphill and/or from a prone position. These shooting conditions can dramatically reduce space allotted for recoil between your eyes and the weapon. **PLEASE** maintain maximum distance when shooting magnum firearms or firearms with heavy recoil. **THE USER ASSUMES ALL RESPONSIBILITY AND LIABILITY FOR HAVING THE RIFLESCOPE PROPERLY MOUNTED TO A FIREARM AND USING THE RIFLESCOPE PROPERLY. ALWAYS CHECK THE CONDITION OF YOUR MOUNTING SYSTEM PRIOR TO USING YOUR FIREARM.**



WARNING:

This product contains natural rubber latex which may cause allergic reactions! The FDA has reported an increase in the number of deaths that are associated with an apparent sensitivity to natural latex proteins. If you are allergic to latex, it is a good idea to learn which products contain it and strictly avoid exposure to those products.

The information provided in this manual is for familiarization purposes only. The contents may undergo further changes with no commitment by Armasight® to notify customers of any updates.

Armasight® assumes no responsibility for any misprints or other errors that this manual may contain.

© Armasight Inc. 2015

 **WARNINGS:**

- It is recommended that you use an eyecup on the eyepiece of the day scope, allowing for the eyepiece diameter and eye relief and having side paddle preferably in order to escape detection.
- The light from the infrared illuminator is invisible to the unaided eye. However, the light can be detected by other night vision devices.

CAUTION:

- Do not dismantle the equipment.
- Keep the equipment clean. Protect it from moisture, dramatic temperature changes, and electric shocks.
- Do not drop or hit the equipment.
- Protect the equipment from overexposure to light: do not activate the equipment in daylight with the objective lens cap removed; do not aim the equipment at bright light sources (fire, car headlights, lanterns, street lamps, room lights, etc.).
- Do not force the equipment controls past their stopping points.
- Do not leave the equipment on during breaks in operation.
- Verify that the equipment is off before installing a battery.
- Do not store the equipment with the battery still in it.
- To avoid deformation or damage, remove the light suppressor from the CO-LR before placing the equipment in storage.
- Thoroughly clean and dry each item before placing them into the storage case.

NOTES:

- Optical axes of the CO-LR and day scope should align. It is not recommended for the distance between the axes to exceed 3mm. If the difference in the axis heights of the CO-LR and day scope above the weapon rail exceeds 3mm, you will need to replace the day scope mounting rings or monoblock.
- The equipment requires some level of ambient light (moonlight, starlight, etc.) to function correctly.
- Performance of the device in nighttime conditions depends on the level of ambient light in the environment. Please remember the following:
 - The level of ambient light is reduced by the presence of clouds, shade, or objects that block natural light (trees, buildings, etc.).
 - The equipment is less effective when operated in shadows and other darkened areas.
 - The equipment is less effective when operated in rain, fog, sleet, snow, dust or smoke.
 - The equipment will not “see” through dense smoke.
- For the purpose of returning defective components, retain all packaging materials.

LIST OF CONTENTS

TITLE	PAGE
Safety Summary	2
List of Contents	4
List of Figures	5
List of Tables	6
How to Use This Manual	6
1. INTRODUCTION	7
1.1 General Information	7
1.1.1 Type of Manual	7
1.1.2 Model Number and Equipment Name	7
1.1.3 Purpose of Equipment	7
1.1.4 Reporting Equipment Improvement Recommendations	7
1.2 Warranty Information and Registration	8
1.2.1 Warranty Information	8
1.2.2 Limitation of Liability	8
1.2.3 Product Warranty Registration	8
1.2.4 Obtaining Warranty Service	9
1.3 Cross References	9
1.4 List of Abbreviations	10
2. DESCRIPTION AND DATA	11
2.1 System Description	11
2.2 Specifications	13
2.3 Standard Components	15
2.4 Optional Equipment	16
2.5 Key Features	17
2.6 System Limitations	17
3. OPERATING INSTRUCTIONS	18
3.1. Installation and Mounting	18
3.1.1 CO-LR Battery Installation	18
3.1.2 XLR-IR850 Battery Installation	19
3.1.3 XLR-IR850 Afocal Doubler Installation	19
3.1.4 Installing the CO-LR on a Weapon Using a Picatinny/ Weaver Rail	20
3.1.5 Clamping Device Adjustment	21
3.1.6 Installing the CO-LR on a Weapon Using The Optional FSRS System	21
3.1.7 Fastening a Advanced Wireless Remote Control to Weapon	23
3.1.8 Installing the IR Illuminator on the CO-LR	23
3.2 Controls and Indicators	24
3.2.1 CO-LR Controls and Indicators	25
3.2.2 IR Illuminator Controls	25
3.3 Operating Procedures	26
3.3.1 CO-LR Operating Procedures	26
3.3.2 Operations XLR-IR850	27
3.3.3 Operating in Changing Light Conditions	28
3.3.4 Shut-Down	28

4. PREVENTIVE MAINTENANCE AND TROUBLESHOOTING	29
4.1 Preventive Maintenance Checks and Services	29
4.1.1 Preventive Maintenance Checks and Services (PMCS)	29
4.2 Operator Troubleshooting	31
4.3 Identification of Operational Defects	31
4.3.1 Operational Defects	31
4.3.2 Cosmetic Blemishes	32
4.4 Maintenance	34
4.4.1 General	34
4.4.2 Cleaning Procedures	34
4.4.3 Battery Removal and Replacement	34
4.5 Return Instructions	35
APPENDIX	36
A. Estimation of Ambient Illumination Level	36
B. CO-LR List of Spare Parts	36
C. Product Warranty Registration Card	38
Alphabetical Index	39

LIST OF FIGURES

FIGURE	TITLE	PAGE
2-1	CO-LR Night Vision Clip-On System	11
2-2	CO-LR Night Vision Clip-On System	12
2-3	Standard Components	15
2-4	CO-LR Optional Equipment	16
3-1	CO-LR Battery Installation	18
3-2	Battery Adapter Positions in the Battery Cap	19
3-3	XLR-IR850 Illuminator. Battery Installation	19
3-4	XLR-IR850 Illuminator with Afocal Doubler	19
3-5	CO-LR Installed on Picatinny Rail of Optional Extended Rail Adapter in Front of Day Scope	20
3-6	CO-LR Mount.	21
3-7	Optional FSRS System. Component Parts	22
3-8	Day Scope Mounted in FSRS system	22
3-9	CO-LR and Day Scope Mounted in FSRS System	23
3-10	Advanced Wireless Remote Control	23
3-11	IR Illuminator	24
3-12	CO-LR Controls	24
3-13	IR Illuminator Controls	25
3-14	IR Illuminator Adjustment	27
4-1	Shading	32
4-2	Edge Glow	32
4-3	Emission Points and Bright Spots	33
4-4	Fixed Pattern Noise	33
4-5	Chicken Wire	34
4-6	Advanced Wireless Remote Control. Battery Installation	35
B-1	CO-LR Spare Parts	36

LIST OF TABLES

TABLE	TITLE	PAGE
2-1	System Description	13
2-2	System Data	13
2-3	Mechanical Data	13
2-4	Electrical Data	13
2-5	Optical Data	14
2-6	Environmental Data	14
2-7	XLR-IR850 Data	14
2-8	Advanced Wireless Remote Control (AWREC) Data	14
2-9	FSRS System Data	15
2-10	Standard Components	15
2-11	CO-LR Optional Equipment	16
3-1	CO-LR Controls and Indicators	25
3-2	IR Illuminator Controls	26
4-1	Preventive Maintenance Checks and Services	29
4-2	Operator Troubleshooting	31
A-1	Standard Natural Light Conditions and Illumination Values	36
B-1	CO-LR Spare Parts List	37

HOW TO USE THIS MANUAL

USAGE

You must familiarize yourself with this entire manual before operating the equipment. Before performing any kind of maintenance on your device, read the section on maintenance in its entirety. Follow all WARNINGS, CAUTIONS, and NOTES.

MANUAL OVERVIEW

The Manual contains sections on operating and maintaining the CO-LR Night Vision Clip-On System. Throughout this Manual, the Armasight CO-LR Night Vision Clip-On System will be referred to as CO-LR, "the equipment," or "the device."

Reference data for the estimation of ambient illumination levels can be found in Appendix A.

A list of spare parts appears in Appendix B.

The Product Warranty Registration Card is located in Appendix C.

INTRODUCTION

1.1 GENERAL INFORMATION

1.1.1 TYPE OF MANUAL

Operation and Maintenance (including a List of Spare Parts).

1.1.2 MODEL NUMBER AND EQUIPMENT NAME

Armasight CO-LR Night Vision Clip-On System
Armasight CO-LR MG Night Vision Clip-On System

1.1.3 PURPOSE OF EQUIPMENT

The CO-LR (Clip On - Long Range) is a night vision system intended for use in conjunction with a day-time sight, or riflescope (here on referred to as a "day scope"). When mounted on a weapon in front of an existing day scope, the CO-LR extends the scope's night vision capabilities up to 1000 yards, without affecting the boresight. Advisable day scope magnification values are 2.5 to 12X (3.5 to 8X are optimal).

The CO-LR is compatible with most commercial and military specification day scopes or binoculars, and fits any Picatinny MIL STD 1913 or Weaver rail via the quick-release mount.

An optional FSRS Front Scope Rail System (here on referred to as the FSRS system) makes it possible to use the CO-LR on a weapon when utilizing a short Picatinny/ Weaver rail mount.

A long-range XLR-IR850 illuminator enables use of the CO-LR in extremely low light conditions or total darkness. Other additional equipment, such as an infrared laser, red dot sight, etc., may also be installed on the CO-LR top Weaver rail.

NOTE:

The CO-LR can also be installed in front of the viewfinders of various instruments to widen the operational illumination range.

1.1.4 REPORTING EQUIPMENT IMPROVEMENT RECOMMENDATIONS

Recommendations from the user for improvements to the device are encouraged.

Mail your comments to Armasight Inc., 815 Dubuque Avenue, South San Francisco, CA 94080, USA.
Or, send an email to info@armasight.com.

1.2 WARRANTY INFORMATION AND REGISTRATION

1.2.1 WARRANTY INFORMATION

This product is guaranteed to be free from manufacturing defects in material and workmanship under normal use for a period of two (2) years from the date of purchase. In the event that a defect covered by the below warranty occurs during the applicable period stated above, Armasight, at its discretion, will either repair or replace the product; such action on the part of Armasight shall be the full extent of Armasight's liability, and the Customer's sole and exclusive reparation. This warranty does not cover a product if it has (a) been used in ways other than its normal and customary manner; (b) subjected to misuse; (c) subjected to alterations, modifications or repairs by the Customer or by any party other than Armasight without prior written consent of Armasight; (d) special order or "close-out" merchandise or merchandise sold "as-is" by either Armasight or the Armasight dealer; or (e) merchandise that has been discontinued by the manufacturer and either parts or replacement units are not available due to reasons beyond the control of Armasight. Armasight shall not be responsible for any defects or damage that in Armasight's view are a result from the mishandling, abuse, misuse, improper storage or improper operation of the device, including use in conjunction with equipment that is electrically or mechanically incompatible with, or of inferior quality to, the product, as well as failure to maintain the environmental conditions specified by the manufacturer. **THE CUSTOMER IS HEREBY NOTIFIED THAT OPERATION OF THE EQUIPMENT DURING DAYLIGHT HOURS OR UNDER ANY EXCESSIVE LIGHT CONDITIONS MAY PERMANENTLY DAMAGE THE INTERNAL COMPONENTS OF THE UNIT AND SAID DAMAGE WILL NOT BE COVERED UNDER THIS WARRANTY.** This warranty is extended only to the original purchaser. Any breach of this warranty shall be enforced unless the customer notifies Armasight at the address noted below within the applicable warranty period.

The customer understands and agrees that except for the foregoing warranty, no other warranties written or oral, statutory, expressed or implied, including any implied warranty of merchantability or fitness for a particular purpose, shall apply to the product. All such implied warranties are hereby and expressly disclaimed.

1.2.2 LIMITATION OF LIABILITY

Armasight will not be liable for any claims, actions, suits, proceedings, costs, expenses, damages or liabilities arising out of the use of this product. Operation and use of the product are the sole responsibility of the Customer. Armasight's sole undertaking is limited to providing the products and services outlined herein in accordance with the terms and conditions of this Agreement. The provision of products sold and services performed by Armasight to the Customer shall not be interpreted, construed, or regarded, either expressly or implied, as being for the benefit of or creating any obligation toward any third party of legal entity outside Armasight and the Customer; Armasight's obligations under this Agreement extend solely to the Customer. Armasight's liability hereunder for damages, regardless of the form or action, shall not exceed the fees or other charges paid to Armasight by the customer or customer's dealer. Armasight shall not, in any event, be liable for special, indirect, incidental, or consequential damages, including, but not limited to, lost income, lost revenue, or lost profit, whether such damages were foreseeable or not at the time of purchase, and whether or not such damages arise out of a breach of warranty, a breach of agreement, negligence, strict liability or any other theory of liability.

1.2.3 PRODUCT WARRANTY REGISTRATION

In order to validate the warranty on your product, Armasight must receive a completed Product Warranty Registration Card for each unit, or the Customer can complete a warranty registration on our website, at www.armsight.com. Please complete the included form (Appendix C) and immediately mail it to our Service Center:

Armasight Inc.
815 Dubuque Avenue
South San Francisco
CA 94080
United States of America.

1.2.4 OBTAINING WARRANTY SERVICE

To obtain warranty service on your unit, the End-User (Customer) must notify the Armasight service department via email. Send any requests to service@armasight.com to receive a Return Merchandise Authorization number (RMA). When returning any device, please take in the product to your retailer, or send the product, postage paid and with a copy of your sales receipt, to Armasight Corporation's service center at the address listed above. All merchandise must be fully insured with the correct postage; Armasight will not be responsible for improper postage or merchandise that becomes lost or damaged during shipment. When sending product back, please clearly write the RMA# on the outside of the shipping box. Please include a letter that indicates your RMA#, the Customer's Name, a Return Address, reason for the return, Contact information (valid telephone numbers and/or an e-mail address), and proof of purchase that will help us to establish the valid start date of the warranty. Product merchandise returns that do not have an RMA# listed may be refused, or a significant delay in processing may occur. Estimated Warranty service time is 10-20 business days. The End-User/ Customer is responsible for postage to Armasight for warranty service. Armasight will cover return postage/ shipping after warranty repair to the End-User/ Customer only if the product is covered by the aforementioned warranty. Armasight will return the product after warranty service by domestic UPS Ground service and/ or domestic mail. Should any other requested, required or international shipping methods be necessary, the postage/ shipping fee will be the responsibility of the End-User/ Customer.

1.3 CROSS REFERENCES

COMMON NAME	OFFICIAL NAME
Allen Wrench	Socket Head Screw Key
Battery Compartment	Battery Box Cover
Shipping Case	Textile Bag
Cotton Swab	Disposable Applicator
Neoprene Jack Plug	Plug Assembly
O-Ring	Gasket
Safety Screw	Electrical Dial-Knob Lock
Pattern Generator	Optical Instrument Reticle
Lens Covers	Exit Port Covers
Paddle Switch	Remote Cable Switch
Batteries	AA
Technical Manual	Operator and Field Maintenance Manual
Tape Fastener Loop	Fastener, Loop Tape
Tape Fastener Hook	Fastener, Hook Tape

1.4 LIST OF ABBREVIATIONS

C	Celsius (Centigrade)
CCW	counterclockwise
Cont'd	Continued
CW	clockwise
Dia	diameter
F	Fahrenheit
FOV	Field of View
g	gram
Gen	Generation
H	Height
hr	hour
IR	infrared
IT	Intensifier Tube
L	Length
LED	Light Emitting Diode
lx	lux
m	meter
mA	milliamperere
min	minute
mm	millimeter
mW	milliwatt
nm	nanometer
No	Number
NV	Night Vision
NVD	Night Vision Device
Para	Paragraph
PMCS	Preventive Maintenance Checks and Services
QRM	Quick Release Mount
QTY	Quantity
RMA#	Return Merchandise Authorization number
s	second
seq	sequence
SR	Service Representative
VDC	Volts Direct Current
V	Volt
W	Width

DESCRIPTION AND DATA

2.1 SYSTEM DESCRIPTION

The CO-LR consists of two primary parts, as shown in Figure 2-1: the night vision device (hereafter referred to as NVD), and the quick release mount system, or mount. The CO-LR is delivered already assembled: the mount (B) should be secured to the rail (A) of the NVD (D) with two screws.

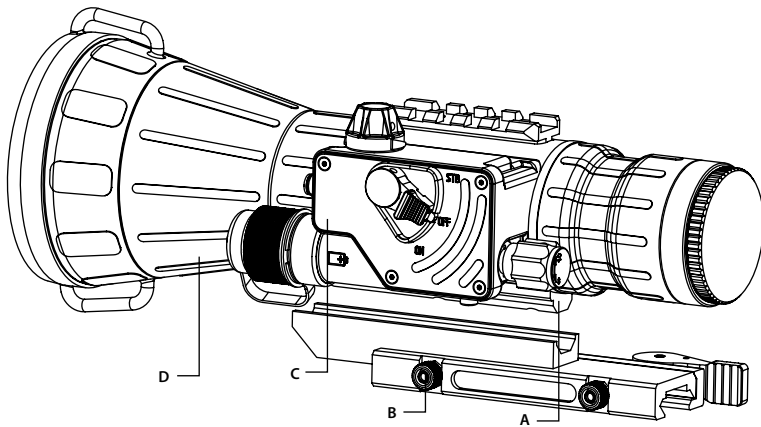

FIGURE 2-1. CO-LR NIGHT VISION CLIP-ON SYSTEM

The optical-electronic system of the NVD includes four main components: the objective and output lenses, an intensifier tube, and the control compartment (C).

The intensifier tube (IT) amplifies the environment's ambient light using a photocathode input lens, which converts light waves and produces a visible image of the scene on the device's screen. The image is projected by the output lens to infinity, and the resulting image is magnified when viewed through the day scope. As such, when the CO-LR is mounted in front of the day scope, it converts the latter into a night vision sight.

The automatic brightness adjustment system maintains consistent image brightness, even in changing light conditions.

The CO-LR MG version incorporates manual gain control, which allows the operator to increase or decrease the brightness of the image to compensate for overly bright or extremely dark conditions.

The bright light protection system controls the existing ambient light through a photoreceiver, and cuts off the IT automatically when the illumination level exceeds the limit of 100-150lx within 20 seconds. The CO-LR turns back on when removed from the excessive light.

Automatic shut-off system automatically turns off the device when it is unused (controls are not touched) for 60 minutes. The automatic shut-off function preserves battery life should the device be inadvertently activated.

The CO-LR is powered by a single AA or CR123A battery.

The CO-LR uses an LED indicator to show the operator when the bright light protection system is activated, or to indicate low battery life.

The Picatinny/ Weaver mount (B) has an adjustable lever-cam clamping device for easy, quick and reliable mounting and removal of the CO-LR.

The CO-LR is shown in Figure 2-2. The ITEM NO. column in Table 2-1 indicates the number used to identify items in Figure 2-2.

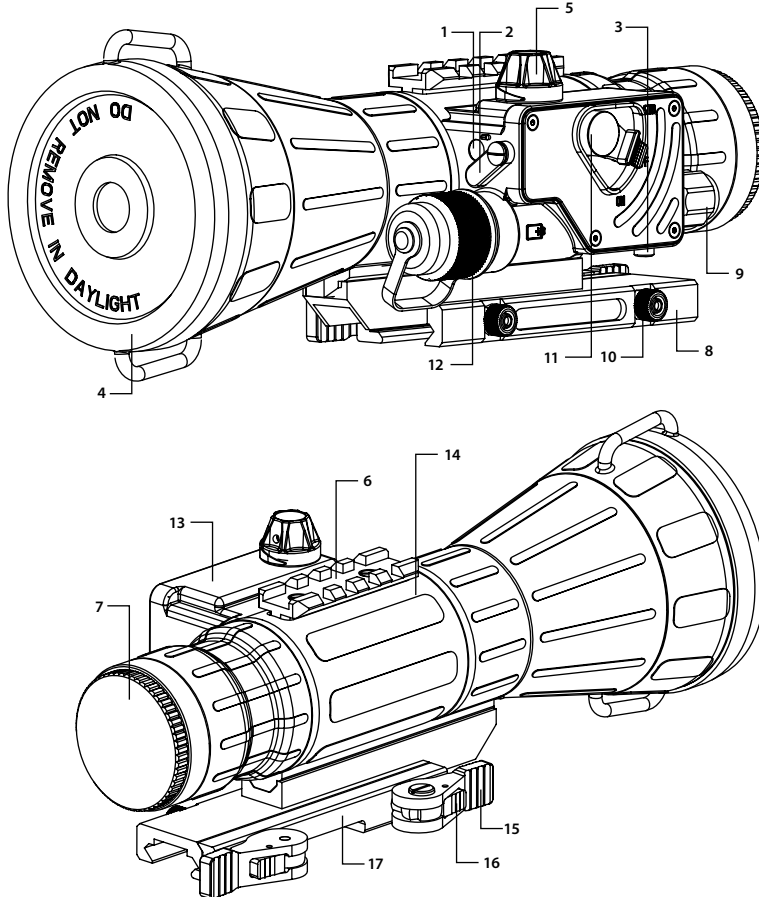

FIGURE 2-2. CO-LR NIGHT VISION CLIP-ON SYSTEM

TABLE 2-1. SYSTEM DESCRIPTION

ITEM	DESCRIPTION	ITEM	DESCRIPTION
1	Photoreceiver	9	Focus Knob
2	Pivoted Shutter	10	Nut
3	Purge Screw	11	Turn Switch
4	Objective Lens Cap	12	Battery Cap with Battery Adapter
5	Gain Control Knob*	13	Control Compartment
6	Top Weaver Rail	14	Main Body
7	Output Lens Cap	15	Cam Lever
8	Double Lever-Lock Quick Release Picatinny Mount	16	Lever Holder
		17	Clamp

* For CO-LR MG version.

2.2 SPECIFICATIONS

TABLE 2-2. SYSTEM DATA

ITEM	DATA
Magnification	Unity (1X)
Boresight Characteristics:	
— Accuracy	0.23 mrad/lp
— Retention	0.19 mrad/lp
— Repeatability	0.16 mrad/lp
System Resolution subject to Tube Resolution:	
— 45 to 54 lp/mm	0.23 mrad/lp
— 55 to 64 lp/mm	0.19 mrad/lp
— Over 65 lp/mm	0.16 mrad/lp

TABLE 2-3. MECHANICAL DATA

ITEM	DATA
Dimensions (L×W×H)	235×97×80 mm (9.25×3.8×3.14 in)
Weight (without Mount and Remote Control)	0.91 kg (2 lbs)
Weight of Mount	0.1 kg (0.2 lbs)
Height of the CO-LR Axis above Weapon Picatinny/Weaver Rail	40 mm (1.57 in)

TABLE 2-4. ELECTRICAL DATA

ITEM	DATA
Battery	Single AA (1.5V) or CR123A (3V)
Cell Life at 20°C	45 hr (3V) / 25 hr (1.5V)
Interrupting Time*	60 minutes

* Optional feature. Interrupting Time setting can be changed at the production stage or the function can be completely disabled.

TABLE 2-5. OPTICAL DATA

ITEM	DATA
Objective Lens Focal Length	108 mm
Objective Lens F/number	1:1.54
Focus Range	10 m to infinity
Field of View	9°
Exit Pupil Diameter	40 mm

TABLE 2-6. ENVIRONMENTAL DATA

ITEM	DATA
Operating Temperature	-40 to +50°C (-40 to 122°F)
Storage Temperature	-50 to +50°C (-58 to 122°F)
Illumination Required	Natural night illumination (overcast starlight to moonlight)
Immersion	10 m for 30 minutes
MIL-STD-810	Complies

TABLE 2-7. XLR-IR850 ILLUMINATOR DATA

ITEM	DATA
IR Emitter Type	LED
Power	1000 mW
Peak Wavelength	850 nm
Illumination Range	up to 1000 m
Divergence	4 to 35°
Battery	Single 18650 Rechargeable Battery (3.7V)*
Battery Life at 20 °C (68 °F)	up to 10 (1/4 Power); 8 (1/2 Power); 6 (3/4 Power); 2.5 (Full Power)
Overall Dimensions (with Mount)	150×48×57 mm (5.9"×1.9"×2.2")
Weight (with Mount, w/o Battery)	264 g (9.3 oz)
Operating Temperature	-20 to +50°C (-4 to 122°F)
Storage Temperature	-50 to +70°C (-58 to 158°F)
Environmental Rating	Water Resistant

* 18650 rechargeable battery and charger are included

TABLE 2-8. ADVANCED WIRELESS REMOTE CONTROL (AWREC) DATA

ITEM	DATA
Type	Wireless Remote Control
Working Range	up to 0.5m
Battery	Single CR2032 Lithium battery (3V)
Battery Life at 20°C (68°F)	Approx. 10,000 clicks
Overall Dimensions	48×39×18mm (1.9×1.5×0.7 in)
Weight (with Battery)	25 g (0.9 oz)
Operating Temperature	-30 to +50°C (-22 to 122°F)
Storage Temperature	-50 to +70°C (-58 to 158°F)
Environmental Rating	Water and Fog-Resistant

TABLE 2-9. FSR SYSTEM DATA

ITEM	DATA
Day Scope Fitting Diameter	34; 30; 25.4 mm
Forward Cant for Extended Range	20 MOA
Space Between Clamps	50 mm
Landing Length on Weapon Picatinny/Weaver Rail	110 mm
Dimensions	414x56x97 mm (16.3x2.2x3.82 in)
Weight	0.590 kg (1.3 lbs)

2.3 STANDARD COMPONENTS

The CO-LR standard components are shown in Figure 2-3 and listed in Table 2-10. The ITEM NO. column indicates the number used to identify items in Figure 2-3.

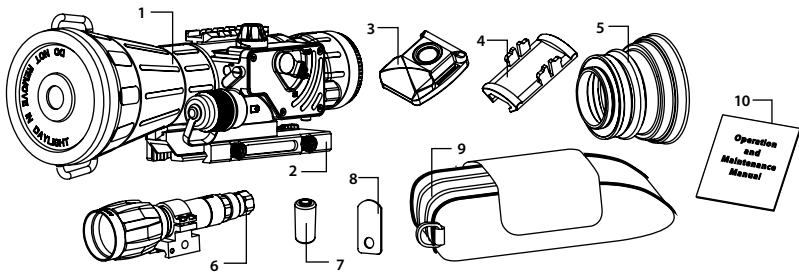

FIGURE 2-3. CO-LR STANDARD COMPONENTS

TABLE 2-10. CO-LR STANDARD COMPONENTS

ITEM NO.	DESCRIPTION	QUANTITY
1	CO-LR Night Vision Clip-On System A night vision device equipped with quick release mount, and that can be installed on a Picatinny/ Weaver rail. Intended for use in conjunction with a day scope.	1
2	Double Lever-Lock Quick Release Picatinny Mount #28 A quick-release mount used to install the CO-LR on a Picatinny/ Weaver rail.	1
3	Advanced Wireless Remote Control Wireless control used to operate the CO-LR in short-time activation mode. Ensures quick and silent CO-LR activation/ deactivation. Delivered with one CR2032 (3V) battery installed.	1
4	Picatinny Adaptor for Advanced Wireless Remote Control A adaptor mounted to the Picatinny rail of an weapon. Allows the Advanced Wireless Remote Control to be installed on the weapon.	1
5	Light Suppressor A rubber cup installed on the CO-LR output lens to reduce light scattering.	1
6	XLR-IR850 Detachable Wide Angle Adjustable X-Long-Range Infrared Illuminator A detachable LED long-range infrared illuminator with a wide, adjustable beam angle. Compatible with night vision devices that rely on CCD or image intensifier technology. Should be used when there is little to no ambient light. Comes fully assembled with a dedicated mount in order to be installed on a Picatinny/Weaver rail. The Riser for XLR-IR (10 mm) #182, 18650 rechargeable battery, and Charger are included.	1

TABLE 2-10. CONTINUED

ITEM NO.	DESCRIPTION	QUANTITY
7	Battery A single battery used to power the unit.	1
8	Special Wrench An instrument used for repositioning the battery adapter in the CO-LR battery cap, depending on the battery being installed.	1
9	Carrying Case A protective case used for storing and carrying of the CO-LR and its accessories.	1
10	Operation and Maintenance Manual Provides safety information, equipment description, mounting procedures, operating instructions, and preventive maintenance checks and services (including a List of Spare Parts).	1

2.4 OPTIONAL EQUIPMENT

Optional items are shown in Figure 2-4 and listed in Table 2-11.

The ITEM NO. column indicates the number used to identify items in Figure 2-4.

The PART NO. column indicates the primary number used by the manufacturer to identify an item.

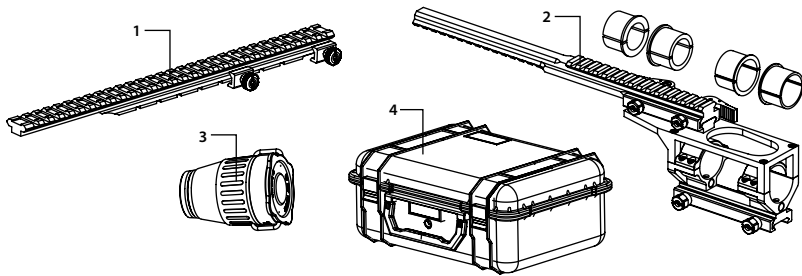

FIGURE 2-4. CO-LR OPTIONAL EQUIPMENT

TABLE 2-11. CO-LR OPTIONAL EQUIPMENT

ITEM NO.	DESCRIPTION	PART NO.
1	Extended Rail Adapter #85 A mounting system used to install a day scope behind the CO-LR on a weapon, using a short-mounting Picatinny/ Weaver rail.	ANAM000045
2	FSRS Front Scope Rail System #38 A mounting system used to install a day scope behind the CO-LR on a weapon, using a short-mounting Picatinny/ Weaver rail.	ANAM000021
3	XLR-IR Afocal Doubler Doubles the distance of XLR-IR850 IR Illuminator beam. Comes complete with an thread adapter #174.	ANAF18XXLR
4	SKB Mil-Standard Hard Shipping/Storage Case A protective case used for shipping/storage of the CO-MINI and its accessories.	ANHC000004

2.5 KEY FEATURES

- Converts your daytime scope, sight, or binoculars into night vision devices
- Mounts in front of any day scope with no re-zeroing required
- Available in a variety of high-performing Gen 2+ and Gen 3 image intensifier tube options
- Wireless remote control
- Automatic brightness control
- Manual gain control for the best possible image contrast in both high and low light conditions (CO-LR MG model)
- Powered by a single AA or CR123A battery
- Bright light cut-off and low battery LED indicators appear in the viewing area of the CO-LR
- Bright light cut-off system
- Automatic shut-off system
- Filled with dry nitrogen to prevent internal fogging
- Mounts on Picatinny/ Weaver rail with a quick release mount
- Mounts on weapons using a short Picatinny/ Weaver rail with the optional FSR system
- Long-range XLR-IR850 illuminator
- Mil Standard compliant
- Limited two-year warranty

2.6 SYSTEM LIMITATIONS

The CO-LR requires some ambient light (moonlight, starlight, etc.) to operate. Factors that can reduce natural night light and negatively affect the efficiency and operation of the CO-LR include: rain, fog, sleet, snow, and smoke; passing cloud cover and objects that produce shadows; and low-contrast environments, such as snow-covered territory, sandy deserts, large bodies of water or grassy hills.

OPERATING INSTRUCTIONS

3.1 INSTALLATION AND MOUNTING

CAUTION:

To protect the intensifier tube when the sight is not in use or when it is being operated in daylight, keep the protective lens cap securely fitted over the lens.

3.1.1 CO-LR BATTERY INSTALLATION

CAUTION:

Ensure that the device is OFF before installing a battery.

Install the battery as follows (refer to Figure 3-1):

1. Unscrew the battery cap (E) and check the position of the battery adapter (D). See Figure 3-2 for the correct positioning of the threaded battery adapter, which changes depending on the battery being installed.
2. If necessary, use the special wrench to change the battery adapter position in the cap.
3. Install the battery (C) into the battery compartment (B). Follow the battery symbol (A).
4. Replace the battery cap (E).

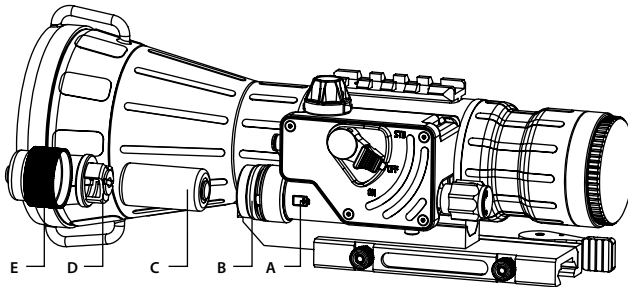

FIGURE 3-1. CO-LR BATTERY INSTALLATION

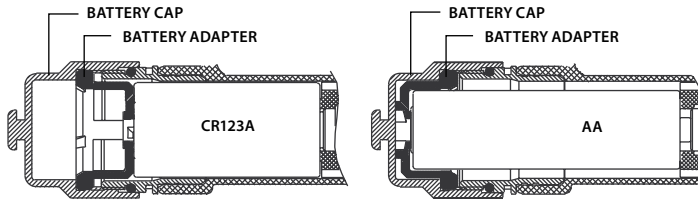

FIGURE 3-2. BATTERY ADAPTER POSITIONS IN THE BATTERY CAP

3.1.2 XLR-IR850 BATTERY INSTALLATION

CAUTION:

Ensure that the IR Illuminator is off before installing the battery.

Fully charge the 18650 rechargeable battery before installing. Insert the battery into charger, aligning the polarity symbols on the battery with the polarity symbols on the charger. Never install the battery backwards.

Connect the power cord to an appropriate power source. An indicator light will flash red when a battery is charging, and will change to green when battery has been fully charged. Remove the battery promptly after charging has been completed.

Install the battery as follows (refer to Figure 3-3):

1. Unscrew the battery cap (A).
2. Install the 18650 rechargeable battery (B) into the battery compartment. Align the polarity symbols on the battery with those on the cap face.
3. Replace the battery cap (A).

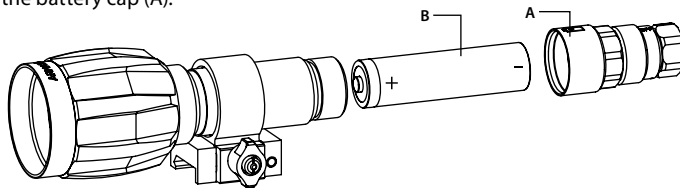

FIGURE 3-3. XLR-IR850 ILLUMINATOR. BATTERY INSTALLATION

3.1.3 XLR-IR850 AFocal DOUBLER INSTALLATION

The XLR-IR850 can be used as hand-held long-range IR illuminator with optional Afocal Doubler.

Attach the magnifying lens to the XLR-IR850 as follows (refer to Figure 3-4):

1. Screw the Afocal Doubler (A) into the threading adapter (B).
2. Screw the Afocal Doubler with adapter into the threading of the XLR-IR850 objective lens (C) housing. Be careful not to over-tighten the lens.

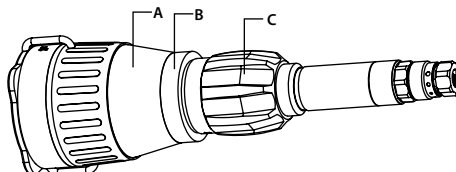

FIGURE 3-4. XLR-IR850 ILLUMINATOR WITH AFocal DOUBLER

NOTE:

The caution notice **DO NOT REMOVE IN DAYLIGHT** on the front lens cap of this universal magnifying lens is not applicable when using it on the XLR-IR850.

3.1.4 INSTALLING THE CO-LR ON A WEAPON USING A PICATINNY/ WEAVER RAIL

! WARNING:

Always make sure your firearm is unloaded before you place the scope on the firearm. Verify that the chamber is empty, particularly if you stop the procedure and resume at a later time. Safe handling rules should be followed at all times.

! WARNING:

It is recommended that you use an eyecup on the eyepiece of the day scope, allowing for the eyepiece diameter and eye relief and having side paddle preferably in order to escape detection.

NOTE:

Optical axes of the CO-LR and day scope should align. It is not recommended for the distance between the axes to exceed 3mm. If the difference in the axis heights of the CO-LR and day scope above the weapon rail exceeds 3mm, you will need to replace the day scope mounting rings or monoblock.

The CO-LR mounted on a Picatinny rail in front of a day scope is shown in Figure 3-5.

To install the CO-LR on a Picatinny/Weaver rail, do the following:

1. Unscrew the output lens cap and place it in the storage case.
2. Remove the light suppressor from the storage case. Screw it into the thread of the output lens in place of the cap.
3. Unlock the clamping device of the CO-LR mount by pushing down on the dog (A, see Figure 3-6) and unlocking the cam lever (B).
4. Install the CO-LR on the Picatinny/Weaver rail in front of the day scope so that the stop (C, see Figure 3-6) slides into one of the rail's transverse slots. The light suppressor should cover the day scope's objective lens.
5. Affix the CO-LR to the rail by locking the cam lever (B, see Figure 3-6).
6. Verify that the clamping device is firmly secured to the CO-LR. If necessary, adjust the clamping device as detailed in Part 3.1.4 (Clamping Device Adjustment).

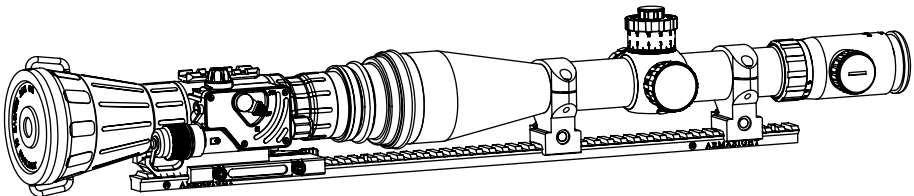

FIGURE 3-5. CO-LR INSTALLED ON PICATINNY RAIL OF OPTIONAL EXTENDED RAIL ADAPTER IN FRONT OF DAY SCOPE

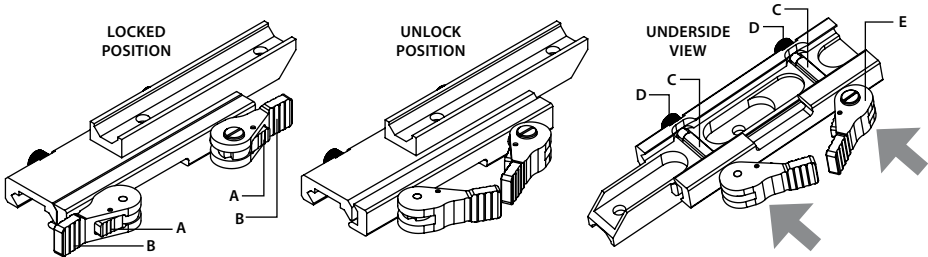

FIGURE 3-6. CO-LR MOUNT

3.1.5 CLAMPING DEVICE ADJUSTMENT

To adjust the mount clamping device, do the following:

1. Remove the CO-LR from the weapon.
2. With the clamping device unlocked (as shown in Figure 3-6), push the cam (E) towards the arrow, which will cause the nut (D) to slide out of its hollow.
3. To tighten/ loosen the clamping device, push down on the cam (E) and turn the nut (D) CW/ CCW respectively, in one-two increments (see note below). Much like when the cam (E) is released, backward-moving springs will cause the nut (D) to slide back into its hollow.

NOTE:

The eight-sided nuts of the mount lever-cam locks will only fit into their hollows if turned in one of the discrete positions using increments equal to $360^\circ/8$.

4. Verify that the adjusted lever-cam lock holds the weapon/ FSRS mounting rail firmly.
5. Repeat the procedure to adjust the clamping device's second lever-cam lock.

3.1.6 INSTALLING THE CO-LR ON A WEAPON USING THE OPTIONAL FSRS SYSTEM

The FSRS system is delivered ready-assembled. The components of the FSRS system are shown in Figure 3-7.

A. Dismantling the FSRS System

Dismantle the FSRS system as follows (see Figure 3-7):

1. Unlock the clamping device (D) and remove the extension mount (E) from the bridge (B).
2. Unscrew the screws (C) and remove the bridge (B) from the mount (H).
3. Unscrew the screws (F) and remove the clamps (G).

B. Mounting the Day Scope

Figure 3-8 shows the day scope mounted to the FSRS system.

Mount the day scope to the FSRS system as follows:

1. Loosen the nuts (A, Figure 3-7). Install the mount (H) on the weapon's Picatinny/ Weaver rail. The two pins of the mount's clamping device should be secured in the transverse slots of the rail. Manually retighten the nuts (A).

NOTE:

Pay attention to the arrow engraved on the right side of the mount (H). The arrow must be pointed towards the end of the weapon muzzle.

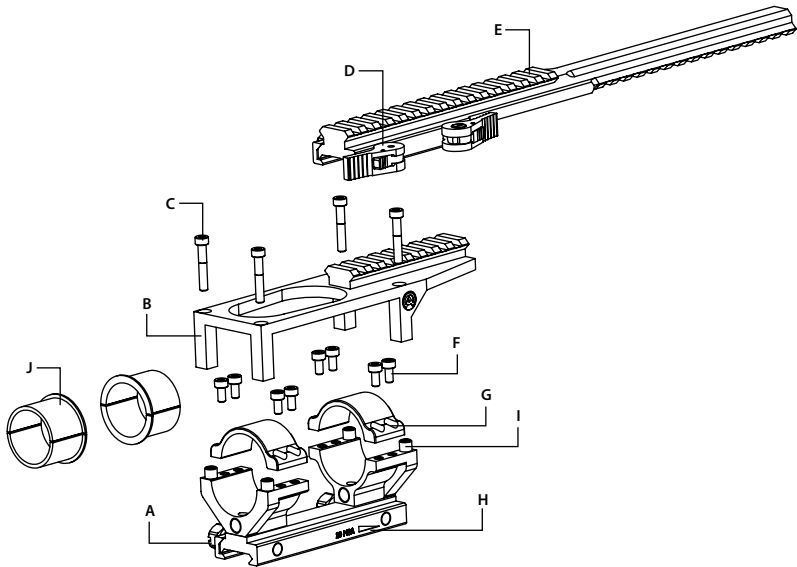

FIGURE 3-7. OPTIONAL FSRS SYSTEM. COMPONENT PARTS

2. Without tightening the screws (F), use the clamps (G) to fasten the scope into the mount (H) with a 34mm diameter, as seen in the preassembled equipment. To mount day scopes with diameters of 30mm or 25.4mm, use the corresponding inserts (J).
3. Adjust or reposition the mount (H) along the weapon rail until you find the most comfortable position over your eye. Readjust until the cross-hairs are level, and are not tilted. After positioning the scope in the mount (H), apply a small amount of thread lock to the threads, and tighten the screws (F) using a 3mm hex key.
4. Tighten the nuts (A) with a screwdriver to secure the mount (H) to the weapon rail.

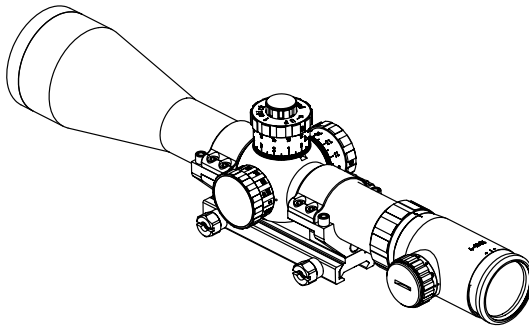

FIGURE 3-8. DAY SCOPE MOUNTED ON FSRS SYSTEM

C. Mounting the CO-LR and Additional Equipment

Figure 3-9 shows the CO-LR and day scope mounted to the FSRS system.

Mount the CO-LR and additional equipment to the FSRS system as follows:

1. Install the bridge (B, Figure 3-7) on the bushes (I, Figure 3-7). After applying a small amount of thread lock to the threads, install and tighten the screws (C, Figure 3-7) using a 3mm hex key.

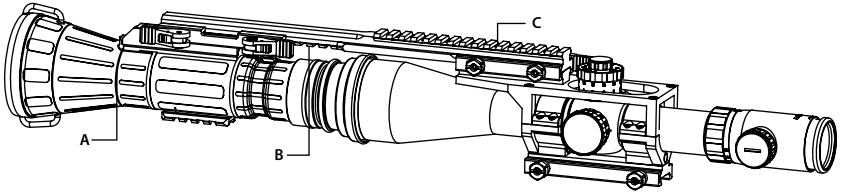

FIGURE 3-9. CO-LR AND DAY SCOPE MOUNTED ON FSRs SYSTEM

2. Unlock the clamping devices (D, Figure 3-7). Install the extension mount (E, Figure 3-7) onto the Weaver rail of the bridge (B). Verify that the clamping device is secured to the extension mount. If necessary, adjust the clamping device as detailed in Part 3.1.3.
3. Install the CO-LR (A, Figure 3-9) onto the Weaver rail (B), underneath the extension mount, as shown in Part 3.1.3.
4. Affix additional equipment to the mount's top Weaver rail (C, Figure 3-9).

After you have completed these steps, remounting the equipment without reinstalling the mount only requires that you remove the extension mount (with the equipment installed) from the bridge.

3.1.7 FASTENING A ADVANCED WIRELESS REMOTE CONTROL TO WEAPON

Using Velcro tape (A, Figure 3-10), fasten the remote control (B) to your weapon in an easily accessible place (e.g., on the front of the rifle stock).

If your rifle has a Picatinny or Weaver rail on the front end, you can use the Picatinny adaptor for the Advanced Wireless Remote (C). Install the adaptor onto the rail (D). Insert the remote control unit into the adaptor.

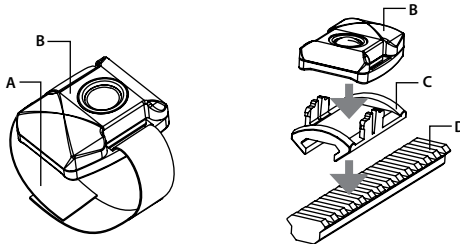

FIGURE 3-10. ADVANCED WIRELESS REMOTE CONTROL

3.1.8 INSTALLING THE IR ILLUMINATOR ON THE CO-LR

Armasight long range IR illuminators are delivered with a dedicated mount, to be installed on the Picatinny/Weaver rail.

To mount an IR illuminator on the CO-LR, do the following (refer to Figure 3-11):

1. With the nut (A) loosened, install the mount (B) on the rail of riser (E) so that the stop (C) slides into one of the transverse slots of the rail.
2. Tighten the nut (A).

NOTE:

The mount clamp (D) has a spherical hinge that allows the IR illuminator to be aligned with the field of view of the CO-LR for maximum effectiveness.

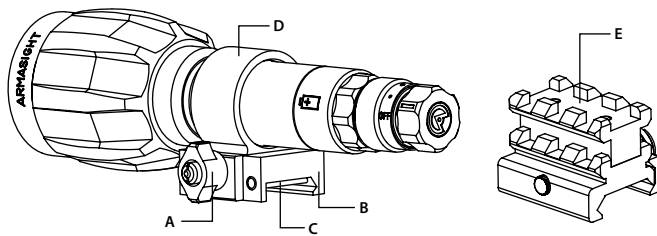

FIGURE 3-11. IR ILLUMINATOR

3. With the nut of riser loosened, install the illuminator on the Weaver rail so that the recoil stop of riser slides into one of the transverse slots of the rail.
4. Tighten the nut of riser.

3.2 CONTROLS AND INDICATORS

CAUTION:

DO NOT force the equipment controls past their stopping points.

3.2.1 CO-LR CONTROLS AND INDICATORS

The CO-LR controls are shown in Figure 3-12.

The CO-LR controls and indicators are defined in Table 3-1. The ITEM NO. column indicates the number used to identify items in Figure 3-12.

The CO-LR controls described elsewhere in this manual (levers and nuts of clamping device) are omitted in this Paragraph.

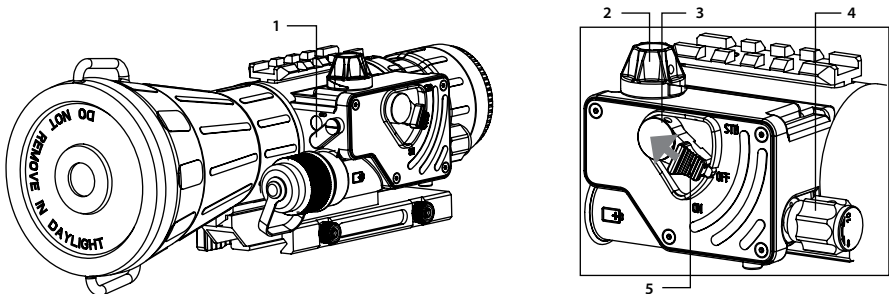

FIGURE 3-12. CO-LR CONTROLS

TABLE 3-1. CO-LR CONTROLS AND INDICATORS

ITEM NO.	CONTROL/INDICATOR	FUNCTION
1	Pivoted Shutter	Closes/ opens the photoreceiver when placed in the highest/ lowest position.
2	Gain Control Knob*	Adjusts the brightness of the image.
3	Turn Switch	Switches on the CO-LR, when turned CW from OFF to ON position. NOTE: Both ON and STB positions can only be entered if the switch is unlocked by pushing the spring-loaded stop (5, Figure 3-12) before turning. Switches the device to standby mode, when turned CCW from OFF to STB (see note above). Switches off the CO-LR, when turned CCW/ CW from ON/ STB to OFF.
4	Focus Knob	Focuses the objective lens. Adjusts for sharpest view of the scene. The total focus range is covered with 1.5 turn of the knob. Directions of focus (sharper to softer) are designated by a double arrow on the knob.
5	Spring-loaded Stop	Locks the turn switch in OFF position.
-	Remote Control Button	Activates/ deactivates the CO-LR in standby when pressed/ released.
-	Built-in LED Indicator	PERMANENT RED GLOW in viewing area indicates excessive light conditions. After 20 s the intensifier will be cut off. The CO-LR turns back again when moved away from the excessive light. FLASHING RED LIGHT in viewing area indicates a low battery. LED flashes three times every 5 minutes.

* For CO-LR MG version only

3.2.2 IR ILLUMINATOR CONTROLS

The controls of the optional IR illuminators are shown in Figure 3-13 and defined in Table 3-3. The ITEM NO. column indicates the number used to identify items in Figure 3-13.

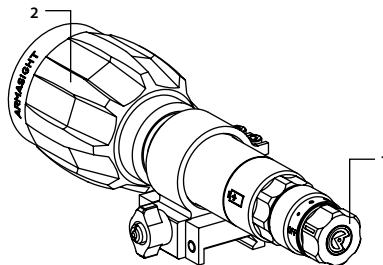

FIGURE 3-13. IR ILLUMINATOR CONTROLS

TABLE 3-2. IR ILLUMINATOR CONTROLS

ITEM NO.	FUNCTION	DESCRIPTION
1	POWER SWITCH	Switches the IR illuminator on/off and adjusts for radiated power. Four ON positions are located between the two OFF positions, and are each marked with a different-sized spot. The larger the spot, the greater the radiated power.
2	LENS FOCUS	Adjusts for IR beam divergence. Adjustment range is covered within approximately one turn of the lens.

3.3 OPERATING PROCEDURES

3.3.1 CO-LR OPERATING PROCEDURES

Operating procedures should be performed in night light conditions only.



WARNING:

Always make sure your firearm is unloaded before you place the scope on the firearm. Verify that the chamber is empty, particularly if you stop the procedure and resume at a later time. Safe handling rules should be followed at all times.

CAUTION:

Use of the CO-LR in brightly lit conditions may damage the image intensifier.

CAUTION:

Pay attention to the caution notice on the objective lens cap: "do not remove in daylight."

1. Verify that the battery is installed as required.
2. Perform a visual estimation of the illumination level in the viewing area, using the reference data presented in Appendix A. You can begin operating the CO-LR if the illumination level is less than 1 lux.
3. Remove the objective lens cap and place it over the lens' housing.

CAUTION:

Before removing the objective lens cap, verify that the photoreceiver is open.

4. Verify that there are no bright light sources in the CO-LR's field of view. Turn the device ON. After a slight delay, a green glow will appear in the day scope's output lens.

CAUTION:

Avoid exposing the device to bright light sources such as firelight, headlights, searchlights, etc., as these can damage the CO-LR.

5. To operate the CO-LR in short-time activation mode, turn the switch to the STB position. To activate the CO-LR, press and hold the remote control button. Release the remote control button to deactivate the CO-LR.

6. Observe the scene. Adjust the focus by rotating the CO-LR focus knob until the image becomes clear and sharp.
7. Adjust the image contrast by rotating the CO-LR gain control knob (CO-LR MG version).
8. If the day scope includes a focusing ring (i.e., parallax adjustment knob), adjust the focus for a parallax-free image.
9. If necessary, turn on the day scope's reticle illumination and adjust the reticle brightness.

CAUTION:

Do not leave the CO-LR activated if it is not being used.

NOTE:

If the automatic shut-off system automatically turns off the device when it is used you need turn the operation switch to OFF position and then back to ON position for continuing the operation.

3.3.2 OPERATING THE IR ILLUMINATOR

Use an IR illuminator when there is little to no ambient light.

CAUTION:

The IR illuminator infrared light will be invisible to the naked eye. The light can, however, be detected by other night vision devices.

CAUTION:

DO NOT leave the IR illuminator activated in the ON position if it is not being used.

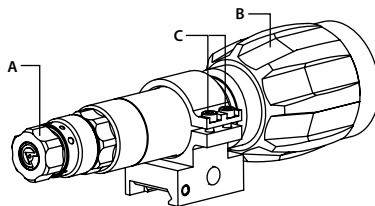

FIGURE 3-14. IR ILLUMINATOR ADJUSTMENT

Operate the IR illuminator as follows:

1. Turn on the IR illuminator by rotating the power switch (A) from OFF position.
2. To change the power level, turn the power switch to one of the spots between the two OFF positions.
3. To adjust IR beam divergence, turn the objective lens of IR illuminator (B).
4. To adjust the IR spot position in the field of view, loosen the two clamp screws (C) and tilt the IR illuminator as required in the spherical clamp hinge. Tighten the screws using a 2.5 mm hex key.

3.3.3 OPERATING IN CHANGING LIGHT CONDITIONS

If a mission must be carried out in changing light conditions, you can deactivate the bright light protection system of the CO-LR. To shut down the protection system, close the photoreceiver by flipping up the pivoted shutter.

CAUTION:

After your mission is complete, open the photoreceiver by flipping the pivoted shutter down.

3.3.4 SHUT-DOWN

Shut-down the CO-LR as follows:

1. Turn the device OFF. The green glow will disappear.
2. Place the cap over the objective lens.
3. Remove the CO-LR from the weapon.
4. Remove the light suppressor from the output lens.
5. Replace the cap on the output lens.
6. Remove the XLR-IR850 from the CO-LR Weaver rail.
7. Remove the battery.

CAUTION:

Do not store the equipment with the battery still in it.

CAUTION:

Remove the light suppressor from the CO-LR to avoid deformation or damage.

8. Ensure that the CO-LR and any accessories are clean and dry before placing them into the storage case.
9. Place the CO-LR and any accessories into the storage case.
10. Store the CO-LR and accessories in the appropriate locations in the case and close the cover.

PREVENTIVE MAINTENANCE AND TROUBLESHOOTING

4.1 PREVENTIVE MAINTENANCE CHECKS AND SERVICES

4.1.1 PREVENTIVE MAINTENANCE CHECKS AND SERVICES (PMCS)

Table 4-1: Preventive Maintenance Checks and Services has been provided so that you can keep your equipment operable and in good condition.

Perform all functional tests in the order listed in Table 4-1.

Operating Procedures are detailed in Chapter 3.

A. Cautions

Always observe any CAUTIONS that appear in the table.

B. Explanation of Table Entries:

SEQ NO. column. Sequence numbers are for reference and appear in the order required to perform checks and services.

LOCATION OF ITEM TO CHECK/ SERVICE column. Indicates the location and the item to be checked or serviced.

PROCEDURE column. Details the check/ service procedure.

NOT FULLY MISSION CAPABLE IF... column. Indicates what faults will prevent your equipment from operating successfully.

TABLE 4-1. PREVENTIVE MAINTENANCE CHECKS AND SERVICES

SEQ NO.	LOCATION OF ITEM TO CHECK/ SERVICE	PROCEDURE	NOT FULLY MISSION CAPABLE IF...
BEFORE OPERATION CHECKS			
1	Completeness	Open the carrying case and inventory items by comparing them with the data specified in this manual.	Items are missing.
2	Body	Inspect for cracks or damage. Scratches and gouges are OK if operation is not affected. Inspect for missing parts (purge screw, knobs).	Cracked or damaged. Purge screw or knob is missing.
3	Objective Lens Cap	Inspect for cracked, torn, or missing lens caps.	Cap is torn or cut. Cup is not secured to the housing of the lens.
4	Output Lens Cap	Inspect for dirt or O-ring damage. Clean as required.	Cap is not held up on the lens housing.

TABLE 4-1. CONTINUED

SEQ NO.	LOCATION OF ITEM TO CHECK/ SERVICE	PROCEDURE	NOT FULLY MISSION CAPABLE IF...
5	Battery Compartment/ Cap / Battery Adapter	Check to make sure the battery adapter is present. Check for corrosion, cap damage or retainer breaks. Check O-ring for cuts or damage.	Retainer is broken. Cap, O-ring or battery adapter is damaged or missing.
6	Switch	Check for operation (without battery).	Switch is inoperative.
7	Lenses	Inspect for cleanliness, scratches, chips or cracks. Clean as required.	Chipped or cracked. Scratches hinder vision through the CO-LR.
8	Photoreceiver	Inspect for cleanliness, scratches. Clean as required.	Photoreceiver is damaged.
9	Focus Knob. Gain Control Knob*	Check to ensure there is free rotation through full range of travel.	Knob is inoperative. Knob is missing
10	Advanced Wireless Remote Control	Check for damage. Check Velcro tape for wear.	Damaged. Unit or tape is missing.
11	Light Suppressor	Inspect for cuts or tears. Check ease of installation and removal.	Light suppressor is torn or cut.
12	Mount	Inspect for damage or corrosion, and for missing parts. Check for proper operation.	Damaged. Some parts are missing. Clamping device is inoperative.
13	XLR-IR850 Body, Mount	Inspect for damage and missing parts. Check for proper operation.	Damaged. Missing parts. Mount is inoperative.
14	XLR-IR850 Battery Cap, Power Switch	Check O-ring for damage. Check for proper operation.	O-ring is damaged or missing. Switch is inoperative.
15	XLR-IR850 Lens	Inspect for cleanliness, scratches, chips or cracks. Clean as required. Check to ensure there is free rotation through the full range of travel (1 turn).	Lens is chipped or cracked. Lens is sticking when or too loose when turned.
16	Optional FRS System	Inspect for damage and missing parts. Check clamping devices for proper operation.	Damaged. Missing of some parts. Clamping devices are inoperative.

OPERATIONAL CHECKS

CAUTION:

The objective lens cap has an optical filter, which allows operational testing of the CO-LR in daylight. Activate the CO-LR in daylight only with the objective lens cap on or in dark conditions.

NOTE:

Daylight checks are described below.

17	CO-LR Switch	Insert the battery. Remove the output lens cap. Close the photoreceiver by flipping up the pivotal shutter. Turn the switch to ON position. Look for green glow (after a slight delay) in viewing area.	No green glow.
		Open photoreceiver by flipping the pivotal shutter down. Look through the output lens and wait about 20 seconds for the green glow to disappear.	Green glow is present, red glow is absent.
18	Remote Control	Put the unit in STB. Press and hold the remote control button. Look for the green glow in output lens. Release the button. Turn the device OFF.	Green glow is absent.
19	Focus Knob	Turn to the device ON. Rotate the knob to ensure it adjusts for focus.	Knob does not adjust for focus.
20	Gain Control Knob*	Rotate the gain control knob to ensure it changes the screen's brightness.	Knob does not adjust the screen's brightness.
21	Viewed Image	Check for flickering, flashing, bright spots, edge glow, shading, or excessive fixed-pattern noise (honeycomb).	Excessive cosmetic defects or fixed pattern noise is present.
22	XLR-IR850	Insert the battery. Mount the XLR-IR850 onto the CO-LR. Turn on the XLR-IR850. Direct the radiated beam at a wall from a distance of about 5m. Look through the CO-LR. A square of light should appear on the wall.	No light appears on the wall.

AFTER CHECKING PROCEDURES

23	Turn off the XLR-IR850 and CO-LR. Replace the protective cap over the CO-LR output lens. Remove the battery. Return the unit and all accessories to the storage case.
----	---

* For CO-LR MG version only

4.2 OPERATOR TROUBLESHOOTING

The purpose of troubleshooting is to identify the most commonly occurring equipment malfunctions, their probable causes, and the corrective actions required to fix them.

Table 4-2 lists common malfunctions that may occur during the operation or maintenance of the CO-LR. Perform the tests, inspections, and corrective actions in the order listed in the table

This table does not list all of the malfunctions that may occur with your device, or all of the tests and corrective actions that may be necessary. If you experience an equipment malfunction that is not listed, or is not fixed by the corrective actions listed in the table, please contact Armasight's Customer Service center.

TABLE 4-2. OPERATOR TROUBLESHOOTING

MALFUNCTION	PROBABLE CAUSE/ TEST/INSPECTION	CORRECTIVE ACTION
Equipment fails to activate.	Battery is missing or improperly installed.	Insert battery or install it correctly.
	Battery is dead.	Replace the battery.
	Battery surfaces or contacts are dirty or corroded.	Clean the contact surfaces with a pencil eraser and/ or alcohol and cotton swabs.
	Advanced Wireless Remote Control is damaged.	Please contact Customer Support.
	Remote control batteries are dead.	Replace the batteries as per Part 4.3.3.2.
	Defective image intensifier.	Please contact Customer Support.
Poor image quality.	Check focus.	Refocus.
	Objective and output lenses dirty.	Thoroughly clean the surfaces of each lens.
	Damaged optical components.	Please contact Customer Support.
LED indicator fails to activate.	Visual inspection.	Please contact Customer Support.
CO-LR affects boresight after installation or during the firing.	Factory alignment broken.	Please contact Customer Support.
Hindered rotation of the battery cap.	Dirty cap thread.	Clean the thread.
	Damaged cap thread.	Please contact Customer Support.
Battery adapter difficult to remove.	Check for damaged battery adapter and battery cap.	If damaged please contact Customer Support.
Light visible around light suppressor.	Align the CO-LR position relative to the day scope.	Reposition the CO-LR on the Picatinny/ Weaver rail.
	Check the light suppressor resilience.	If light suppressor is defective please contact Customer Support.
XLR-IR850 fails to activate.	Battery is missing or improperly installed.	Insert battery or install it correctly.
	Battery is dead.	Replace the battery.
	XLR-IR850 damaged.	Please contact Customer Support.

4.3 IDENTIFICATION OF OPERATIONAL DEFECTS

4.3.1 OPERATIONAL DEFECTS

Operational defects relate to the reliability of the intensifier, and are an indication of instability. If identified, the user will need to return the CO-LR immediately. Operational defects include shading, edge glow, flashing, flickering, and intermittent operation.

A. Shading

If shading is persistent, you will not be able to see a fully circular image (Figure 4-1). Shading is a very dark, high-contrast area with a distinct line of demarcation present, and you cannot see an image through it. Shading always begins on the edge, and will eventually migrate inward until it spans across the entire image area. If you notice shading with your device, please contact Customer Support.

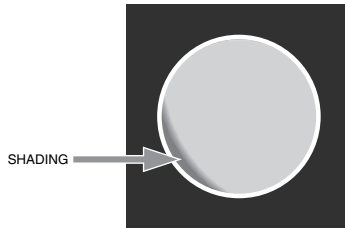

FIGURE 4-1. SHADING

NOTE:

Verify that any shading is not the result of improper eye-relief adjustment.

B. Edge Glow

Edge glow is a bright area (it sometimes appears to be coloring) in the outer portion of the viewing area (see Figure 4-2). To check for edge glow, block out all light from the device by cupping a hand over the lens. If the image tube is displaying edge glow, the bright area will still show up; if edge glow occurs, please contact Customer Support.

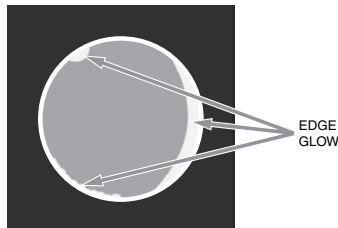

FIGURE 4-2. EDGE GLOW

C. Flashing, Flickering, or Intermittent Operation

The image may appear to flicker or flash. If there is more than a single flicker, check for a loose battery adapter or a weak battery. If flickering continues, please contact Customer Support.

4.3.2 COSMETIC BLEMISHES

Cosmetic blemishes are usually the result of manufacturing imperfections. They **do not** affect the reliability of the image intensifier, and are not normally a cause for returning the CO-LR. However, some types of cosmetic blemishes can worsen over time and interfere with the user's ability to properly operate the device during missions. If you believe a cosmetic blemish is cause for returning the device, record the specific nature of the problem on the maintenance forms and use the clock method to identify the position of the blemish and its approximate distance from the center (e.g., 5:00 toward the outside, 2:30 near the center, or 1:00 midway).

The following are examples of cosmetic blemishes:

A. Bright Spots

A bright spot is a small, non-uniform bright area that may flicker or appear constant (Figure 4-3).

Not all bright spots make the CO-LR returnable. Cup your hand over the lens to block out all light. If the bright spot remains, please contact Customer Support.

Bright spots usually go away when all light is blocked out. Verify that any bright spots are not simply the result of bright light in the area you are observing. Bright spots are acceptable if they do not interfere with the user's ability to view the scene or perform missions.

B. Emission points

Emission points are steady or fluctuating pinpoints of bright light in the image area that do not go away when all external light is blocked from the objective lens (Figure 4-3). The position of an emission point within the image area does not move. Not all emission points are cause to return the CO-LR. Verify that emission points are not simply light sources present in the scene you are observing. Emission points are acceptable if they do not interfere with the user's ability to perform missions.

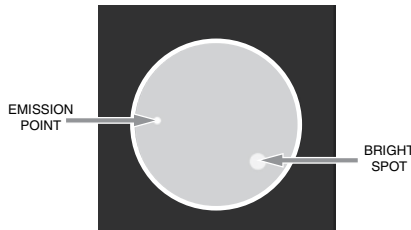

FIGURE 4-3. EMISSION POINTS AND BRIGHT SPOTS

C. Black Spots

Black spots are cosmetic blemishes in the image intensifier or debris between the lenses. Black spots are acceptable as long as they do not interfere with the user's ability to observe the scene. No action is required if this condition is present, unless the spots interfere with the operator's ability to perform missions.

D. Fixed-pattern Noise

Fixed-pattern noise is usually a cosmetic blemish characterized by a faint hexagonal (honeycomb) pattern that appears throughout the viewing area. This typically occurs in excessively lit environments or when viewing very bright lights (See Figure 4-4). This pattern can be seen in every image intensifier if the level of light is high enough. This condition is acceptable as long as the pattern does not interfere with the user's ability to view an image or interfere with their ability to perform missions.

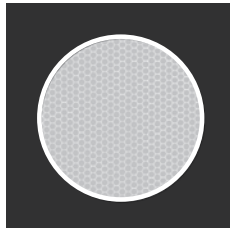

FIGURE 4-4. FIXED-PATTERN NOISE

E. Chicken Wire

Chicken wire is an irregular pattern of dark thin lines that can appear in the field of view, either throughout the image area or in sections of the image area (See Figure 4-5). In the worst-case scenario, these lines will form hexagonal or square, wave-shaped lines. No action is required if this condition is present, unless it interferes with the user's ability to view the image or their ability to perform missions.



FIGURE 4-5. CHICKEN WIRE

4.4 MAINTENANCE

4.4.1 GENERAL

The section regarding CO-LR operator maintenance consists of operational tests, inspections for unit serviceability, cleaning and mounting procedures, troubleshooting, and replacement instructions for a limited number of parts. Maintenance instructions covered elsewhere in this manual (PMCS, troubleshooting, etc.) are not repeated in this section.

CAUTION:

The CO-LR is a precision electron-optical instrument, and must be handled carefully at all times to prevent damage to the device's body or mechanisms.

4.4.2 CLEANING PROCEDURES

CAUTION:

Thoroughly dry each item before placing them into the storage case.

Clean the CO-LR as follows:

1. Gently brush off any dirt from the unit's body using a clean, soft cloth.
2. Moisten the cloth with fresh water and gently wipe external surfaces (**except** for glass surfaces).
3. Dry any wet surfaces (**except** for glass surfaces) with another clean, soft, dry cloth.
4. Using a lens brush, carefully remove all loose dirt from the glass surfaces.
5. Slightly dampen a cotton swab with ethanol. Gently and slowly wipe the lenses (including the photoreceiver and the pivotal focusing lens). Without touching the lens holders, clean the glass surfaces in circular movements, beginning in the center and moving out towards the edge. Change the cotton swab after each circular stroke. Repeat until the glass surfaces are clean.
6. Clean the battery contact surfaces and contact springs with a pencil eraser and/ or alcohol-dampened cotton swabs.

Clean optional devices with a soft brush (cloth), soap, and water as required.

4.4.3 BATTERY REMOVAL AND REPLACEMENT

Refer to Part 3.1.1 for the CO-LR and XLR-IR850 battery installation procedure.

Replace the remote control battery as follows:

1. Using a screwdriver, unscrew the four screws (A, Figure 4-6) that affix the cover to the bottom of the unit. Remove the cover.

2. Replace the battery with new one (CR2032, 3V). Stack the battery in its place under the leaf contact spring with the minus contact directed towards the electric board, as the minus sign etched on the board indicates.
3. Replace the cover and retighten the screws (A).

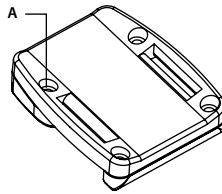

FIGURE 4-6. ADVANCED WIRELESS REMOTE CONTROL BATTERY INSTALLATION

4.5 RETURN INSTRUCTIONS

For service, repair or replacement, please email: service@armasight.com.

To assist the Service Representative (SR) with determining whether or not an item is repairable, please provide the following information:

1. Serial Number of the defective item. This is engraved on the CO-LR rail (A, Figure 2-1).
2. Thorough description of the malfunction, defect or damage.
3. An explanation of how the malfunction, defect or damage occurred, if known.

If the SR determines that the item is under warranty or should be returned for repair, a Return Material Authorization number (RMA#) will be provided. RMA can be obtained via e-mail to service@armasight.com or via phone by calling Armasight Customer Service at (888)959-2259 Ext. 2 or via fax (888)959-2260.

When returning the CO-LR for service or repair, the following procedures should be done to prevent any additional damage:

1. Verify that the CO-LR is free of all contaminants, such as dirt or any other foreign material.
2. Remove the battery.
3. Place the cap over the objective lens.
4. Screw the cap onto the output lens.
5. Place the CO-LR and its accessories into the shipping case.6. Place the CO-LR and a copy of the test report or detailed description of the failure in a suitable packing/ shipping container. Mark the package with the RMA#. Ship using a fast, traceable service. Shipping must be prepaid by the Customer.

A. ESTIMATION OF AMBIENT ILLUMINATION LEVEL

Table A-1 lists some common natural light conditions and their corresponding representative illumination values.

TABLE A-1. STANDARD NATURAL LIGHT CONDITIONS AND ILLUMINATION VALUES

STANDARD NATURAL LIGHT CONDITIONS	ILLUMINATION VALUE, LUX
Quarter moon	0.05
Full moon	0.30
Late twilight sky	1.00
Twilight sky	10.00
Overcast sky in the daytime	500.00

B. LIST OF SPARE PARTS

The parts authorized in the below list of spare parts are required for operator maintenance. This list includes parts that must be removed in order to replace authorized parts.

The ITEM NO. Column indicates the number used to identify items in Figure B-1.

The PART NO. Column indicates the primary number used by the manufacturer to identify an item; this number controls the design and characteristics of the item by means of its engineering, specifications, standards, and inspection requirements.

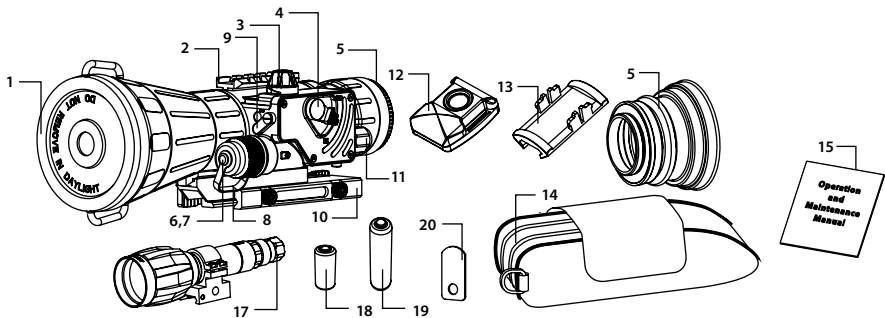

FIGURE B-1. CO-LR SPARE PARTS

TABLE B-1. CO-LR LIST OF SPARE PARTS

ITEM NO.	DESCRIPTION	PART NO.
1	Objective Lens Cap	COLROLC
2	Top Weaver Rail	COLRWR
3	Gain Control Knob *	COLRGCK
4	Turn Switch	COLRTS
5	Output Lens Cap	COLROLC
6	Battery Cap	COLRBC
7	Battery Adapter	COLRBA
8	Battery Cap Retainer	COLRBCR
9	Pivoted Shutter	COLRPS
10	Double Lever-Lock Quick Release Picatinny Mount #28	COLRQRM
11	Focus Knob	COLRFK
12	Advanced Wireless Remote Control	ANWR000001
13	Picatinny Adapter for Advanced Wireless Remote Control	ANRA000002
14	Carrying Case	COLRCC
15	Operation and Maintenance Manual	COLROMM
16	Light Suppressor	COLRLS
17	XLR-IR850 Detachable Long Range Infrared Illuminator	IAIR850IR000003
18	CR123A Lithium Battery	CR123A
19	AA Alkaline Battery	ALT
20	Special Wrench	COLRSW

* For CO-LR MG version only

C. PRODUCT WARRANTY REGISTRATION CARD

In order to validate the warranty on your product, Armasight must receive a completed Product Warranty Registration Card for each unit, or the user must complete warranty registration on our website (www.armsight.com). Please complete the included form and immediately mail it to our Service Center: Armasight Inc., 815 Dubuque Avenue, South San Francisco, CA 94080, USA

ARMASIGHT PRODUCT WARRANTY REGISTRATION CARD

PRODUCT INFORMATION

Product Name _____ Purchased From _____

Purchase Date _____ Product Serial # _____

CUSTOMER INFORMATION

Name _____

Address _____

City _____ Country _____ Zip _____

Day Phone # _____ Home Phone # _____

E-mail address _____

.....
Customer Signature Required

ALPHABETICAL INDEX

A

Abbreviations 10

B

Battery Installation 18

Black Spots 33

Bright Spots 33

C

Cautions 2

Cell Life 13

Chicken Wire 33

Cleaning 34

Cosmetic Blemishes 32

E

Edge Glow 32

Emission Points 33

F

Fixed-Pattern Noise 33

Flashing, Flickering, or Intermittent Operation 33

Focus (Objective Lens) 25

G

General Information 7

H

Height 13

I

IR Illuminator 15, 24, 27

L

Length 13

M

Maintenance 29, 34

Mounting 18

O

Operating Instructions 18

Operational Defects 31

Operator Troubleshooting 31

P

PMCS 29

S

Safety Summary 2

Shading 32

Shut-down 28

Spare Parts 36

System Description 11

S

Turn Switch 13, 25

W

Warranty Information 8

Weight 13



Armasight Inc.

815 Dubuque Avenue,
South San Francisco
CA 94080, USA

Phone: (888)959-2259

Fax: (888)959-2260

Intl Phone/Fax: (650)492-7755

info@armasight.com



WARNING:

This product contains natural rubber latex which may cause allergic reactions! The FDA has reported an increase in the number of deaths that are associated with an apparent sensitivity to natural latex proteins. If you are allergic to latex, it is a good idea to learn which products contain it and strictly avoid exposure to those products.

www.armasight.com