

FOXBAT-5

NIGHT VISION BI-OCULAR



The AGM FoxBat-5 night vision bi-ocular is the perfect tool for mid-range and long-range observation. The FoxBat-5 combines a single high quality image intensifier tube with image beam splitter, double eyepiece and reliable electronics.

The FoxBat-5 is a magnified, high-grade night vision device built around a high-performance image intensifier tube. The high-light shut-off feature ensures that the high-quality image intensifier tube is protected from over-exposure. The FoxBat-8 is powered by two AA batteries and its typical operating time on a single battery load is up to 40 hours of continuous use.

AGM FoxBat-5 provides sufficient and durable solution for long time viewing sessions and mid to long range observation. This night vision bi-ocular is the ideal choice for home security, recreational use and even for scientific projects.

Nature observers will enjoy the combination of crystal-clear image and professional fast multicoated optics. AGM FoxBat-5 has tripod mounting option so the longest night will not be an issue for birdwatchers and jaegers.

- 5x magnification
- Super-fast, multi-coated, all-glass optics
- Dual eye viewing system for long viewing sessions
- Rugged and versatile design
- Water and fog resistance
- Ergonomic and easy to operate controls
- Detachable long-range IR illuminator
- Tripod mountable
- 3-year warranty

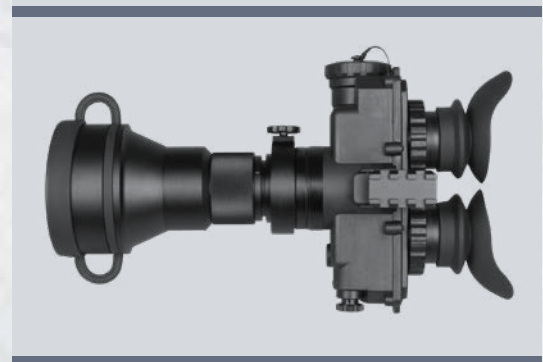

SPECIFICATIONS

Image Intensifier Tube	Gen 2
Magnification	5x
Lens System	140 mm; F/2.0
FOV	9.4°
Focus Range	10 m to infinity
Diopter Adjustment	-5 to +5 diopters
LED Indicators	- Low Battery - Excessive Light Conditions
Automatic Brightness Control	Yes
Bright Light Cut-Off	Yes
Infrared Illuminator	Detachable long-range IR illuminator
Battery Type	Two 1.5V AA batteries
Battery Life (Operating)	Up to 40 hrs
Operating Temperature Range	-40°C to +50°C (-40°F to +122°F)
Storage Temperature Range	-50°C to +70°C (-58°F to +158°F)
Weight	1070 g (2.35 lb)
Overall Dimensions	280 × 150 × 78 mm (11.0 × 5.9 × 3.0 in)
Package Includes	Night Vision Bi-ocular, Detachable IR Illuminator, Tripod with Adapter, Neck Strap, Lens Cloth, User Manual, Hard Case

Specifications are subject to change without notice.
Images are for illustration purposes only.



MAIN OFFICE | 173 West Main Street | PO Box 962 | Springerville, AZ 85938, USA
Tel. +1.928.333.4300 | info@agmglobalvision.com | www.agmglobalvision.com

EUROPEAN OFFICE | #6 Andrey Lyapchev Blvd | Sofia, P.C. 1756 | Bulgaria
Tel. +35.988.560.0326 | info@agmglobalvision.eu | www.agmglobalvision.eu

www.agmglobalvision.eu